



**KING'S CROWN™**  
ticket dispenser



# Operators Manual

[www.bingoking.com](http://www.bingoking.com)

# **King's Crown™ Pull Tab Dispensing Machine**

**For All Cash Accepting Models**

**Version 1.0**

**January 2007**

**©2007 Bingo King Co. All Rights Reserved.**

**Bingo King Co.  
2807 Lincoln Way  
Lynnwood, WA 98087  
phone: 425.745.3700**

# Table of Contents

<b>Introduction .....</b>	<b>1</b>
<b>1. Overview .....</b>	<b>3</b>
What You Should Know .....	3
Important Safety Information.....	4
Damage Action Process .....	4
Unpacking.....	5
Check Your Shipment.....	5
<b>2. Installation .....</b>	<b>6</b>
Choosing a Location .....	6
Wall-Mounting the Unit.....	6
Surface Mounting the Unit .....	6
Opening the Cabinet Doors .....	7
Connecting the Battery.....	7
Disconnecting the Battery.....	7
About the Alarm .....	7
<b>3. Preparation.....</b>	<b>9</b>
Turning On the Unit.....	9
Turning Off the Unit.....	10
Loading Tickets.....	10
Removing Tickets .....	11
Displaying Sample Tickets .....	11
<b>4. Basic Operation.....</b>	<b>12</b>
Accessing Menus .....	12
Managing Personal Identification Numbers (PINs) .....	13
Tracking Sales.....	13
Establishing Column Ticket Pricing.....	14
Testing the Dispensing Unit.....	15
Setting the Date & Time .....	15
Tracking Door Openings .....	16
Reading The Dispenser's Serial Number .....	17
Clearing Established Credits.....	17
Resetting Error Messages.....	18
Emptying the Cash.....	21
<b>5. Optional Report Printer .....</b>	<b>22</b>
Generating the Report.....	22

<b>6. Player Information .....</b>	<b>24</b>
Dispensing Tickets .....	24
<b>7. Care and Maintenance .....</b>	<b>25</b>
Lubricating the Chute Door .....	25
Lubricating the Accelerator Roller Shafts.....	26
Cleaning The Infrared Sensor .....	27
Cleaning The Bill Validator.....	28
Cleaning the Coin Acceptor .....	28
Clearing Jammed Bills.....	28
Replacing a Ticket Column.....	29
Adjusting For Different Ticket Thickness.....	31
Random Number Generator Features .....	32
<b>8. Troubleshooting.....</b>	<b>33</b>
Bill Validator Diagnostics.....	35
<b>9. Specifications .....</b>	<b>36</b>
Physical Characteristics.....	36
<b>10. Diagrams and Pictures .....</b>	<b>37</b>
Column Exploded View.....	37
Bill Acceptor Door Assembly .....	38
Roller Carriage Assembly.....	38
Keypad Assembly.....	39
Printed Circuit Board Layout .....	40
Parts List, Column.....	41
Parts List, Main Cabinet.....	42
<b>11. Warranty .....</b>	<b>44</b>

# Introduction

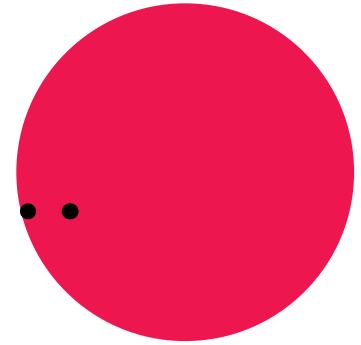

Your new King's Crown™ Pull Tab Dispenser is designed using state of the art technology. Its rugged all steel construction, modular design, and exceptional user convenience set it apart from the competition. Benefits include: accurate sales recording, complete security, reduced staff requirements, high speed dispensing, and the capability to play a variety of tickets.

The King's Crown Pull Tab Dispenser features 1000 ticket capacity per column, vends one, three, four, five, or six window tickets.

The bill validator accepts \$1.00, \$5.00, \$10.00, and \$20.00 denominations and holds a maximum of 600 bills. The coin acceptor (if installed) accepts 25 cent & \$1.00 coins in the United States, and 25 cent, \$1.00 and \$2.00 coins in Canada. Your King's Crown Pull Tab Dispenser is capable of tickets that sell for \$0.10, \$0.25, \$0.50, \$1.00, \$2.00 or \$5.00 denominations.

A "Play All" button enables the user to play all existing credits from any one column up to a maximum of 100 tickets.

The King's Crown Pull Tab Dispenser offers quick front loading of tickets, and individual modular ticket columns that may be easily removed for service without affecting the operation of other columns.

Security features include: separate keys for tickets and money, an alarm to prevent unauthorized access and theft, and on random select models and models with the printer update kit installed automatic date and time tracking of the last 30 door openings.

Cash totals and sales totals are stored in both resettable and non-resettable electronic memory, and are backed up by non-resettable electro-mechanical meters. The electronic memory will hold even when power has been disconnected.

An optional printer upgrade kit allows a single printer to generate hard copy reports of accounting information for any number of dispensers.

The King's Crown Pull Tab Dispenser offers many years of trouble-free service. However, should a problem arise, our service department will provide timely response on repairs, spare parts, and technical support.

Information in this document pertains to this release of the Bingo King Co. Inc. King's Crown™ Pull Tab Dispenser. Modifications are periodically made to the information: any such changes will be reported in subsequent revisions.

The laws that determine the legality of this product change constantly. It is the responsibility of the buyer to determine which products are legal in any given area.

All trademarks, trade names, and patents are the property of their respective companies.



**TECHNICAL ASSISTANCE CENTER**

*Providing Proactive Solutions  
Through Quality Service and Support*

Support Hours: 8:00 AM to 12:00 AM EST

**866.405.3482 • [www.bingoking.com](http://www.bingoking.com)**

# Overview

## Chapter

# 1

Read this manual completely before you begin. The information provided in this document describes the procedures required for successful operation of this unit.

Throughout this manual, you will see . Pay particular attention to these sections. If you do not follow the instructions correctly, you may adversely affect the operation of your dispenser.

### What You Should Know

Before you begin, familiarize yourself with the information in this manual and your model of King's Crown™ Pull Tab Dispenser. Note the following important details:

- The keypad located inside the model is used to maintain the unit.
- You must have a valid Personal Identification Number (PIN) to maintain the unit.
- You should not share your PIN number with others.
- Players cannot dispense tickets if the machine door is unlocked.
- The King's Crown Pull Tab Dispenser accepts cash from 25 cent coins to \$20.00 bills, depending upon the model of your machine.
- Players cannot enter money when a credit of greater than \$80.00 has been established. The green light on the bill collector turns red and no currency is accepted.
- The bill collector indicator turns green and accepts money once the credits are reduced to \$80.00 or less.
- When the player presses the "PLAY ALL" button and then presses a column button, up to 100 tickets dispense at the column price selected and the remaining credits are displayed. If the price per ticket in the column selected is not evenly divisible by the credits entered, a credit displays after the tickets are dispensed. Enter more money to dispense a ticket for a credit that does not equal the cost of tickets in the machine. For example, if a \$5.00 credit appears in a machine containing only \$2.00 tickets, two \$2.00 tickets dispense and a \$1.00 credit appears. Another \$1.00 is required to dispense the remaining ticket.
- Pressing only one column button allows players to dispense one ticket at a time.
- After each ticket is vended, the remaining credit amount displays in the LCD (liquid crystal display).
- If you have any questions, call your Bingo King Co. distributor or Bingo King Co. for assistance.

## Important Safety Information



Some caution must be exercised when using the King's Crown™ Pull Tab Dispenser. Be sure to read and understand the following important information to ensure safe and prolonged operation of the unit:

- Do not install or use the machine near water or moisture. Take care not to spill any liquids on the machine.
- Do not use any abrasive materials or solvents to clean the machine.
- Do not drop retaining plates in between the ticket columns when removing. A short circuit could result, causing serious damage to the product.
- Do not spill oil on the rubber surfaces of the rollers when lubricating.
- Do not use a metal crevice tool to vacuum the inside of the unit unless the power is off.
- Use a plastic crevice tool to vacuum inside the unit when the machine is plugged in.
- Use a soft damp cloth with a drop of liquid fabric softener to clean the glass on the unit.
- Use any light lubricant in a precision oiling tool to lubricate the rollers, transfer bottom shaft and the chute door.

---

### DAMAGE ACTION PROCESS

Your Bingo King Co. equipment contains delicate electronic equipment. It is imperative that you thoroughly inspect the contents of the package before accepting product delivery from the carrier.

In case of severe damage, refuse the equipment from the carrier. Contact your local Bingo King distributor for immediate replacement.

If the product is damaged but acceptable, make a note on the bill of lading before accepting. Take a photo of the damage before and after unpacking as a record of claim against the carrier. Contact the carrier's agent immediately for inspection. Be sure to obtain a copy of the inspection report for your records.

If these precautions are not taken, we cannot assist you in recovering the amount of the claim against the carrier.



## **Unpacking**

To unpack your dispenser, set box upright on a firm level surface. Cut the shipping straps, and lift off the top and remove packaging material. Now dispenser can be moved from the bottom carton to the permanent location.

Take note of the keys and the manual to keep in a safe place.

In order to protect the columns and main door glass during shipping, the adjustable backs of the columns have been taped in place. You should remove the tape before using your dispenser so that you can properly adjust the columns for different ticket lengths. Unlock the main door with the keys supplied, and carefully peel off the tape on the sides of each column.

Also, remove the cardboard packing from the bill acceptor bill box and remove the cardboard strip from the bill pathway before use.

Whether you wall mount or surface mount the dispenser, keep in mind that a 4-column unit weighs 110 pounds, and an 8-column unit weighs 190 pounds. Use care and get assistance before unpacking and lifting. A minimum of two people are required.

## **Check Your Shipment**

First, ensure that your shipment contains the following:

- The correct model of the King's Crown™ Pull Tab Dispenser which you have ordered.
- Power supply for ticket dispenser.
- Two keys to open the cabinet doors
- Two keys to open the bill acceptor and coin collectors (coin collectors are available on selected models only)
- One H-shaped retaining plate per dispensing column
- Leveling feet (you receive four leveling feet with a four column dispenser and eight leveling feet with an eight column dispenser)
- Coin box (if your dispenser is equipped with a coin collector)

Contact your local Bingo King Co. distributor if you do not have any of the above items.

### **NOTE:**

In order to validate your warranty, you must present proof of purchase to the Bingo King Co. Keep a sales receipt or invoice to protect your investment. (See warranty section for details on page 44).

# Installation

## Chapter

# 2

### Choosing a Location

Before using your King's Crown™ Pull Tab Dispenser, you must ensure that it is properly installed and ready for use. It is important that you position the unit in a safe and secure location. Make sure that your location:

- Provides accessibility to an electrical outlet to plug in the unit.
- Remains dry.
- Allows the user to reach the unit when selecting the wall-mounting option.
- Provides a level surface on which to place the unit when choosing to operate the unit from a table, counter or shelf.
- Provides ample room for both the upper and lower cabinet doors to swing open to the left, to the right, or both.

### Wall-Mounting the Unit

If you decide to wall-mount the unit, choose a location that allows you to open both the upper and lower cabinet doors after the unit has been mounted. Note that each four-column model weighs approximately 110 pounds before any tickets are loaded. Keep this in mind when deciding where to mount the unit. Also, consider that the height of individual users varies when deciding how high to place the unit.

The unit is designed for wall-mounting based on a 16 inch stud spacing (4 column machine). You require four 5/16 inch diameter lag bolts (or a bolt to fit your wall application) and a socket wrench with extension. Open the cabinet doors. Insert the lag bolts through the mounting eyes in the back of the unit and secure the bolts into the wall.

### Surface Mounting the Unit

The dispenser is easily installed on a level surface like a table, counter or shelf. If your surface is not completely level, you can adjust the unit using the leveling feet provided. The leveling feet also protect the surface on which you mount the unit.

Secure the unit to its location using lag bolts or nuts and bolts. Each leg contains a hole designed to allow you to secure the unit in place with a 5/16 inch bolt.

## Opening the Cabinet Doors

The upper cabinet door contains two locks for security. You must unlock the upper door before opening the lower cabinet door. To open the lower cabinet door, release the lever on the latch located just above the lower cabinet door.

## Connecting the Battery

When you first receive your King's Crown Pull Tab Dispenser, the battery inside the unit will not be connected. If you would like the battery connected, connect the leads as shown in the diagram.

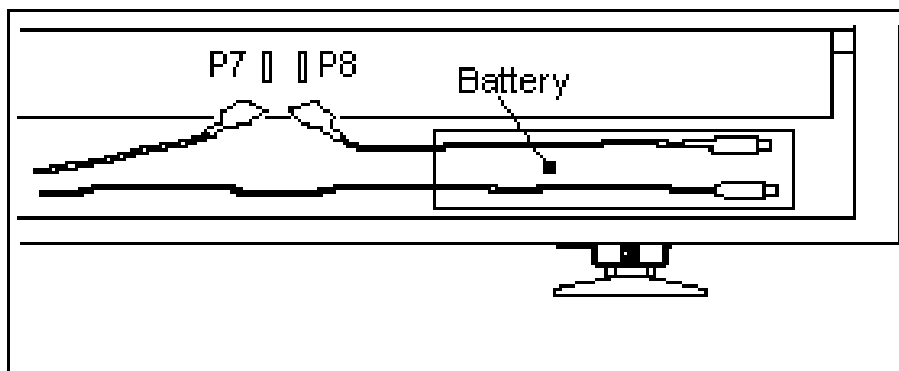

Plug in the two connectors as illustrated. The display on the console will now read ALARM ACTIVATED ENTER PIN NUMBER.

## Disconnecting the Battery



You must disconnect the battery if you are shipping the unit or if the AC power will be shut down for more than 96 hours. Disconnect connector P7 and place it in the plastic holder to the left. This will prevent the battery from possibly shorting out.

## About the Alarm

The King's Crown Pull Tab Dispenser is fully alarmed to prevent unauthorized access to the machine and theft.

The alarm operates on a seven second delay and sounds under the following conditions:

- Any door is opened.
- The AC power is disconnected.

Note that on the initial power up of the dispenser, the alarm may also sound.

To clear an alarm, open the cabinet door and enter your four digit pin number.

**NOTE:**

If you do not wish to have the alarm sound during a power failure, you should not connect the battery inside the unit. By doing this, however, the alarm will not sound during a theft of the machine, and if a player has credits established when the power fails, the player will not be able to continue playing until power to the dispenser is restored. If you choose to do this, make sure that you place the connector in the plastic holder provided to prevent accidental short circuits.



# Preparation

## Chapter

# 3

### Turning On the Unit

Once the machine is safely secured to a surface and the battery is connected:



1. Attach the power supply connector to the left side of the machine. This connector only fits in one way: **do not use force**. Plug in the power supply (plug) to a 120V outlet. **It is recommended that you plug your dispensing machine into a surge-protected circuit or use a good quality surge-protected power bar.**
2. Press the On/Off switch located under the unit on the left-hand side. (The LCD backlighting and the interior cabinet lighting will turn on when the unit is switched on.)
3. Unlock and open the cabinet doors.
4. If this is the first time you are using the dispenser, and the unit either has the optional printer upgrade kit installed or is a random column select dispenser, the LCD will prompt you to enter the date and time. See page 15 for instructions on setting the date and time. The dispenser will also prompt you to enter the date and time after all power has been disconnected from the unit and then reconnected.
5. The LCD will now appear as follows:

**ALARM ACTIVATED  
ENTER PIN NUMBER**

6. Enter your four digit PIN number.

**Note that the King's Crown Pull Tab Dispenser is pre-programmed with PIN number 1000 in position #5.**



If this is the first time you are using the dispenser, you must set the column ticket prices before you can dispense tickets. If you lock the cabinet door before establishing ticket prices, the LCD displays the following:

**PRICING NOT SET  
GO TO SERVICE**

You must unlock the cabinet door and set the ticket pricing. See page 14 for details.

If the cabinet door is locked and ticket pricing is set, players can purchase tickets.

## Turning Off the Unit

Use the On/Off switch located on the bottom left corner of the machine to turn off the unit. Turning off the unit does **not** affect any of the column price settings, electronic totals or PIN number entries, nor does turning off the unit affect the battery backup. If you are going to store the machine for more than 96 hours, disconnect the battery (see page 7).

## Loading Tickets

The King's Crown™ Pull Tab Dispensers can be adapted to fit one window, three window, four window, five window, and six window ticket types, where approved by the government. The tickets vary in size. You can adjust each column to the appropriate ticket size and load up to 1000 tickets per column.

1. **Adjust the dispensing column size**, if necessary. Use the tabs located on the back of each column to make the adjustment.

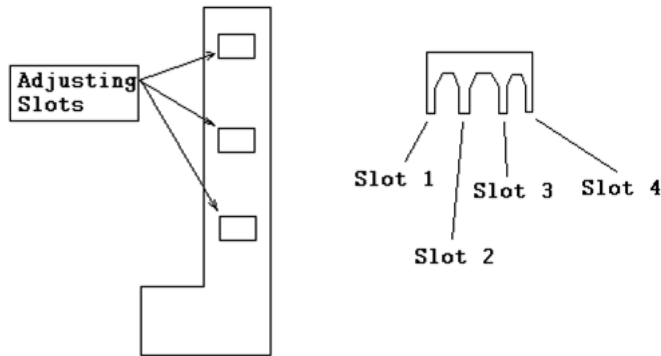

- Pinch the upper right-hand tab of the column you wish to adjust.
- Pinch the bottom left-hand tab of the same column.
- Lift the tabs to release from the positioning slots.
- The closest slot (slot #1) is used for 2 5/8" ticket lengths. Slot #2 is used for 3 1/4" ticket lengths. Slot #3 is used for 3 3/4" - 3 7/8" ticket lengths. Slot #4 is for 4 3/8" ticket lengths.

2. **Load a single ticket.** Make sure that both the upper and lower cabinet doors remain open.

Starting at the top of the column, slide a ticket down the chute until it reaches the lowest point. Rotate the large white gear at the bottom right of the column to advance the front edge of the ticket approximately one half to one inch into the feeder. No further adjustments for size are required. The front edge of the ticket remains lower than the back edge. **Notice that the ticket is sitting in the column at an angle.**



3. **Fill the column.** First, check to see how the tickets bend. To prevent tickets from jamming and to ensure that tickets vend smoothly, make sure the tickets are loaded as illustrated. Reference label on inside of cabinet door for ticket loading.

If there is a bend in your tickets, the bend should be pointed down.

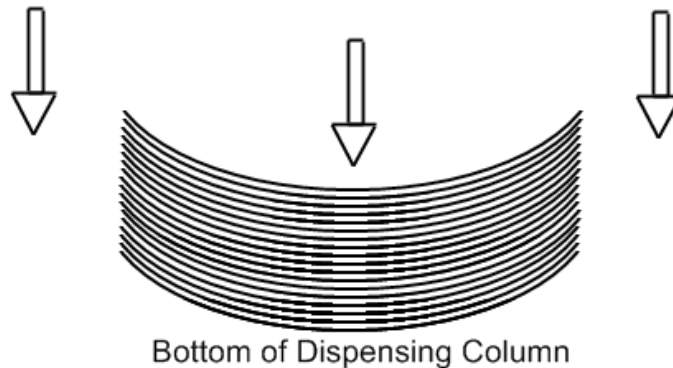

A wide opening at the top of each column allows you to enter stacks of tickets. Grasp a manageable stack of tickets. Slide the stack down the chute. Continue to load tickets until the column is full. **All tickets in one column must be of the same value.**



#### 4. Replace the retaining plate.

Once the column is filled, you must ensure that tickets placed in the wide entry slot do not fall out. Use the retaining plates (shaped like an H) to secure the tickets as follows:

- Place one hand in front of the tickets loaded in the top part of the column.
- Take the H-shaped retaining plate in the other hand.
- Insert the retaining plate in the slots at the top and behind the guide bar at the bottom.
- Lock the retaining plate into the slots at the top of the column.

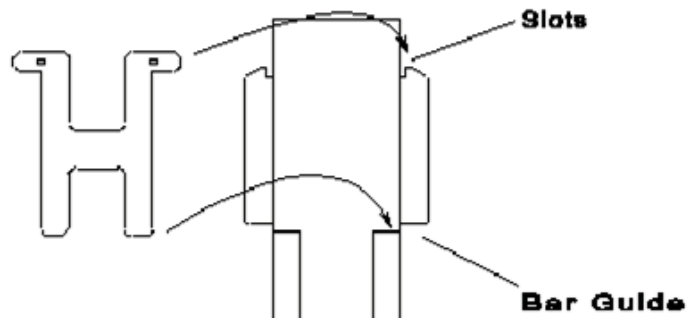

### Removing Tickets

You can remove any tickets that do not load properly down the chute. Remove the H-shaped retaining plate. Slide the ticket or tickets back up to the top and out the wide entry opening. Reload the tickets. Replace the retaining plate.

### Displaying Sample Tickets

A double sided reusable tape is provided with each machine. Place the tape on the inside of the window in front of the column you wish to display a ticket. Next, press the ticket onto the tape with the graphic side facing the glass so that it is visible when the door is closed. The ticket will have the illusion of floating on the glass as the tape is nearly invisible. To change tickets, gently remove the old ticket and attach a new ticket to the tape.

# Basic Operation

## Accessing Menus

The LCD (liquid crystal display) located above the bill validator provides the menu information for maintaining your King's Crown™ Pull Tab Dispenser.

When the doors are locked and the machine is ready to dispense tickets, the LCD appears as follows on models that accept **only bills**:

<p><b>INSERT MONEY</b> <b>\$1.00 TO \$20.00</b></p>
---

When the doors are locked and the machine is prepared to dispense tickets, the LCD appears as follows on models that accept **both coins and bills**:

<p><b>INSERT MONEY</b> <b>\$0.25 TO \$20.00</b></p>
---

To set up or make changes, unlock the upper cabinet door and use the keypad located inside the door to program the changes. Once you open the door, the ENTER PIN NUMBER prompt displays.

If you are using the dispenser for the first time, enter PIN number **1000** and then press #. Otherwise, enter your own PIN number and press #. The Main Menu will then appear:

<b>PINS-1</b>	<b>TOTALS-2</b>
<b>PRICE-3</b>	<b>MORE-#</b>

Pressing # will bring the following display:

<b>TEST-4</b>	<b>CLOCK-5</b>
<b>DOOR-6</b>	<b>PRINT-7</b>

Pressing \* will return you to the previous screen.



- Enter **0** to clear credits that have not been played. See page 17.
- Enter **1** to add, change or delete PIN numbers. See page 13 (see below).
- Enter **2** to view the total number of tickets dispensed for each column and an accumulated total, as well as the total currency collected. See page 13 (see below).
- Enter **3** to set ticket prices for each column. See page 14.
- Enter **4** to dispense tickets in a test mode. See page 15.
- Enter **5** to set the date and time. See page 15.
- Enter **6** to display the last 30 door openings in reverse chronological order. See page 16.
- Enter **7** to print out an accounting report. See page 22.
- Enter **8** for serial number entry (use if PRICING NOT SET, GO TO SERVICE to hold changes after resetting machine).

## Managing Personal Identification Numbers (PINs)

You can add, change or delete up to five different PIN numbers. **You cannot access menu functions unless at least one PIN position contains a valid PIN number. 0000 is not a valid PIN number.** Press 1 to select the PIN function. The PIN Menu displays.



To add or change a PIN number, press \*. NEW PIN displays. Enter the new PIN number or enter 0000 to delete a PIN number for that position. Press the # key to advance to the next position. After you modify the PIN number, press the # key. When you reach the last PIN position, the display returns to the Main Menu.

<b>POS</b>	<b>PIN</b>
<b>00</b>	<b>0000</b>

## Tracking Sales

The King's Crown Pull Tab Dispenser records the total number of tickets dispensed from each column and provides a sum total of all tickets dispensed. In addition, the dispenser accumulates a total of all currency accepted. To review the Totals Menu, press 2 from the Main Menu.

<b>TOTAL FOR COLS-1</b>
<b>TOTAL FOR CASH-2</b>

To display the total ticket sales, press 1, TOTAL FOR COLS. The total for the first column displays, where xx is the column number and 0000000 displays the actual number of tickets dispensed from that column. **This amount is not erasable or resettable.**

<b>TOTAL</b>	<b>COL XX</b>
<b>0000000</b>	

**When you press # again, the resettable total appears.** Pressing \* will reset the total. Press # to advance to the next non-resettable column total. Pressing # again will advance you to the next resettable total. Once all columns are displayed, press # to display the non-resettable TOTAL ALL COLUMN amount. Press # again to display the resettable TOTAL ALL COLUMN amount.

<b>TOTAL ALL COLUMN</b> <b>0000000</b>
---

Note that the King's Crown Pull Tab Dispenser is also equipped with two meters located inside the main cabinet door. The TOTAL ALL COLUMN amount equals the amount displayed on the bottom meter.

**To track the total value of currency accepted,** press 2, TOT FOR CASH, from the Totals Menu. The following screen displays, where \$0000000.00 is the actual currency total:

<b>TOTAL CASH</b> <b>\$0000000.00</b>
--

Press # to proceed to RESETTABLE TOTAL CASH. Pressing \* resets the cash total to zero, while pressing # returns you to the main menu.

Note that the top meter located inside the main cabinet door matches the TOTAL CASH amount. If your machine accepts 25¢ coins, the top meter amount will be accurate within 75¢. For example, \$475.75 appears as \$475.00.

### **Establishing Column Ticket Pricing**

The King's Crown Pull Tab Dispenser is shipped with six preset ticket values: ten cents, twenty-five cents, fifty cents, one dollar, two dollars or five dollars. Players select amounts to match the ticket value. **You must set the column amounts to equal the value of the tickets placed in the column.**



- Columns are numbered from left to right, beginning with column 1 on the far left.
- A column must display a value greater than \$0.00 to dispense tickets.
- A column must contain all tickets of the same value; for example, all tickets in column one must cost \$0.50.
- Set the price for the tickets one column at a time.
- If the price set for the column does not match the price of the ticket, sales will not correctly represent the price of the ticket.



From the Main Menu, Press 3. The Pricing Menu appears:

Press the \* key to select a preset value. When the proper amount displays, press the # key to advance to the next column. Repeat this step until all of the columns are priced. When you have finished

entering the ticket prices, press the # key to return to the Main Menu. **All columns must have pricing set in order for the dispenser to enter vend mode.**



**NOTE:** On random select models, a minimum of two columns must be set to the same price before the unit can dispense tickets.

### **Testing the Dispensing Unit**

The test feature allows you to ensure that tickets dispense accurately without affecting the actual total counters. Use the test mode to empty a column or columns prior to loading a different ticket type or prior to transporting the machine. Note the following:

- The total number of tickets dispensed displays while in this mode.
- You cannot test vend more than 100 tickets at a time.
- If you request more tickets than are available in the column, the column empties, the column dispensing mechanism shuts off and the total number of tickets dispensed displays.
- Totals do not accumulate in memory.
- Columns are numbered from left to right, beginning with column 1 on the far left.

From the Main Menu, press 4. The Test Vend Menu appears.

**SELECT COLUMN  
000 PRESS #**

Close the lower cabinet door.

1. Enter the test column number.
2. Enter the number of tickets you want to dispense.
3. Press # for tickets to dispense into the stacking compartments.

### **Setting the Date & Time (Random Column Select or Printer Upgrade Installed Only)**

From the Main Menu, press 5. If your dispenser is not a random column select or does not have the optional printer upgrade kit installed, the following will appear:

After a short delay, the LCD will automatically return to the Main Menu.

**CLOCK OPTION  
REQUIRED**

(Contact your local Bingo King Co. distributor if you would like this option.)

Otherwise, the date and time currently in the unit will display:

**FRI APR 17 2003  
00:00:00 PRESS #**

Pressing # will return you to the Main Menu whereas pressing \* will allow you to set a new date and time.

Press \*, and the following screen will appear:

<b>MONTH:</b> <b>PRESS #</b>
---------------------------------

Enter the applicable month in numerals (e.g.: Jan - 01, Feb - 02, etc.) and then press #, and the following screen appears:

<b>DATE:</b> <b>PRESS #</b>
--------------------------------

Enter the correct date (1-31) and press #. The following screen appears:

<b>YEAR:</b> <b>PRESS #</b>
--------------------------------

Enter the correct year (i.e.: 2003) and press #. The following screen appears:

<b>ENTER HOURS:</b> <b>PRESS #</b>
---------------------------------------

Enter the correct hour in 24-hour format (i.e.: 0-23) and press #. The following screen appears:

<b>MINUTES:</b> <b>PRESS #</b>
-----------------------------------

Enter the correct minutes (0-59) and press #. The following screen will show the changes you have made:

<b>FRI APR 17 2003</b> <b>11:46:45 PRESS #</b>
---

Press # to return to the main menu.

From the Main Menu press 5 to re-check the date and time settings. The date and time will re-display. If they are correct, press # to return to the Main Menu, otherwise press \* to enter the correct date and time.

## **Tracking Door Openings**

On units that are either random column select or have the optional printer upgrade kit installed, the dispenser automatically tracks the date and time of the last 30 door openings in reverse chronological order. (Contact your local Bingo King Co. distributor if you would like this option.)

From the Main Menu press **6**. If your dispenser is not a random column select unit or does not have the optional printer upgrade kit installed, the following will appear:

**CLOCK OPTION  
REQUIRED**

After a short delay, the LCD will automatically return to the Main Menu. (Contact your local Bingo King Co. distributor if you would like this option.)

Otherwise, the following screen will appear:

**FRI APR 17 2003  
00:00:00 POS# 01**

This shows the date and time of the last door opening by the person with a valid pin number in position # 1 (See page 13 for details on PIN numbers and Positions).

Pressing # will show you the second last door opening. Pressing # again will show you the third last door opening, and so on.

At any time while viewing door openings, pressing \* will return you to the Main Menu.

If an invalid PIN number was entered upon opening the door, the display will show:

**FRI APR 17 2003  
00:00:00 POS# 00**

The date and time when the invalid PIN number was entered. Note that a valid POS # was not entered.

## **Reading the Dispenser's Serial Number**

From the Main Menu, press **8**. The machine's serial number will appear on the LCD which will match the serial number on the identification tag on the lower left hand side of your unit. Pressing # will take you back to the Main Menu.

## **Clearing Established Credits**

If you wish to clear any credits established in the dispenser without dispensing tickets, from the Main Menu press **0**, and the following will appear on the LCD:

**CLEAR CREDITS  
1 - YES 2 - NO**

Press **1** if you want to clear the established credits or **2** if you do not.

**NOTE:** Only the available credits are cleared. The amount of cash recorded as being received will not clear and this will not match with the number of tickets sold.



## Resetting Error Messages

Error messages appear for two reasons: a ticket column is empty or a malfunction in a column has occurred. This section describes how to correct the problem in each of these situations. The first time the problem is detected, the LCD displays the total number of credits remaining:

**\$0.00 CREDIT**

If the player selects again from the same column, the LCD displays the following prompt:

**COLUMN EMPTY  
OR MALFUNCTION**

When the message appears because an empty column has been selected, another column must be chosen if the player wishes to continue.

### To reset the message before resuming play:

1. Unlock and open the upper cabinet door.
2. Enter your PIN number.
3. Load tickets. (See page 10 for details.)
4. Close and lock cabinet door.
5. Resume play.

**Note that when you reload the column with tickets, the player does not lose any credits.**

If the message appears for a reason other than an empty ticket column, you must first determine the reason for the malfunction. Tickets will not dispense for one of three reasons: **a ticket jam, a misaligned sensor, or a dirty sensor** (refer to pages 19, 20 and 27).

**To reset an error message resulting from a ticket jam:**

1. Unlock and open the upper cabinet door.
2. Enter your PIN number.
3. Locate the column with lodged ticket.
4. Turn the large white gear to the right of the column with the jam until the ticket can be removed.
5. Remove the ticket.
6. Close and lock cabinet door.
7. Resume play.

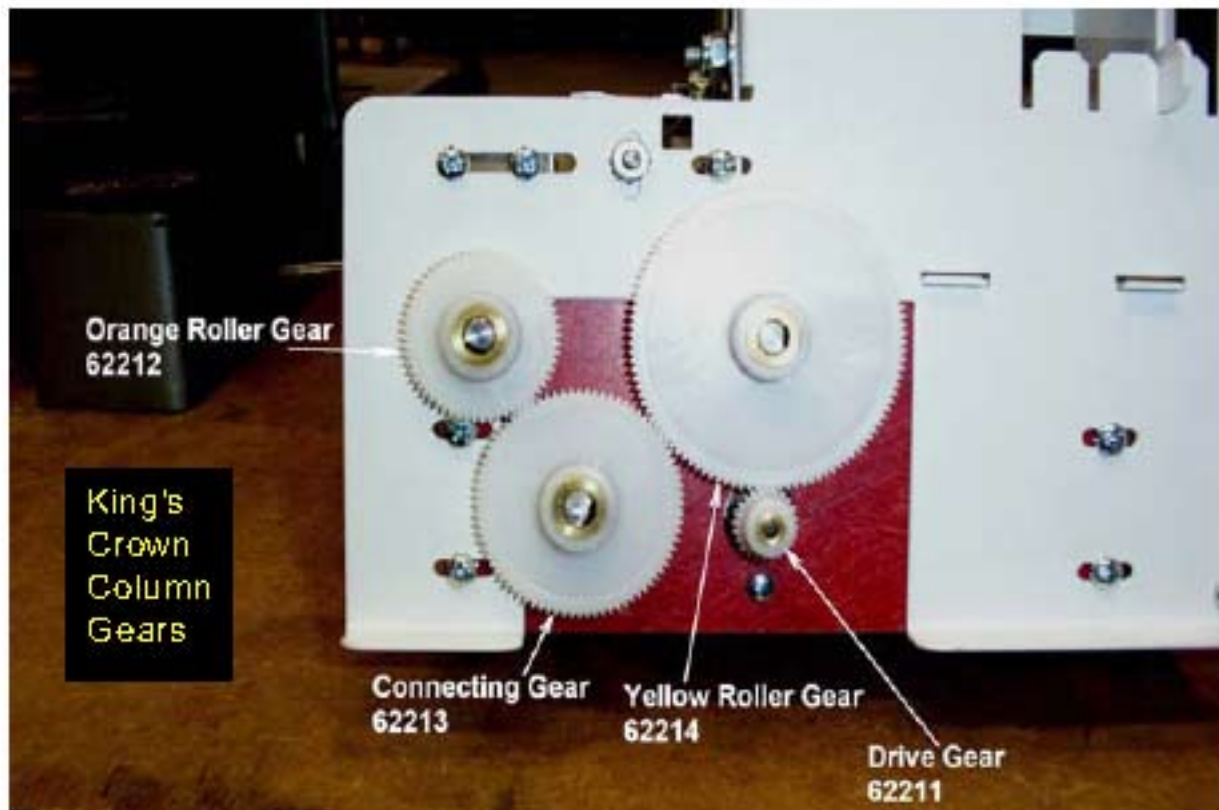

**To reset an error message caused by misalignment of a sensor:**

1. Unlock and open the upper cabinet door.
2. Enter your PIN number.
3. Determine which sensor is out of alignment. Note that the sensor must face down towards the ticket.
4. Remove the guard above the sensor by removing the nut attaching the guard with a 5/16" open end wrench.
5. Align the sensor above but not touching the ticket. The bottom of the sensor is 1/8 inch to 1/4 inch above the ticket. Use a 1/4 inch wrench and a Phillips screwdriver to tighten. The sensor's location is as follows:
6. Reinstall the sensor guard.
7. Test the column (see page 15).
8. Close and lock cabinet door.
9. Resume play.

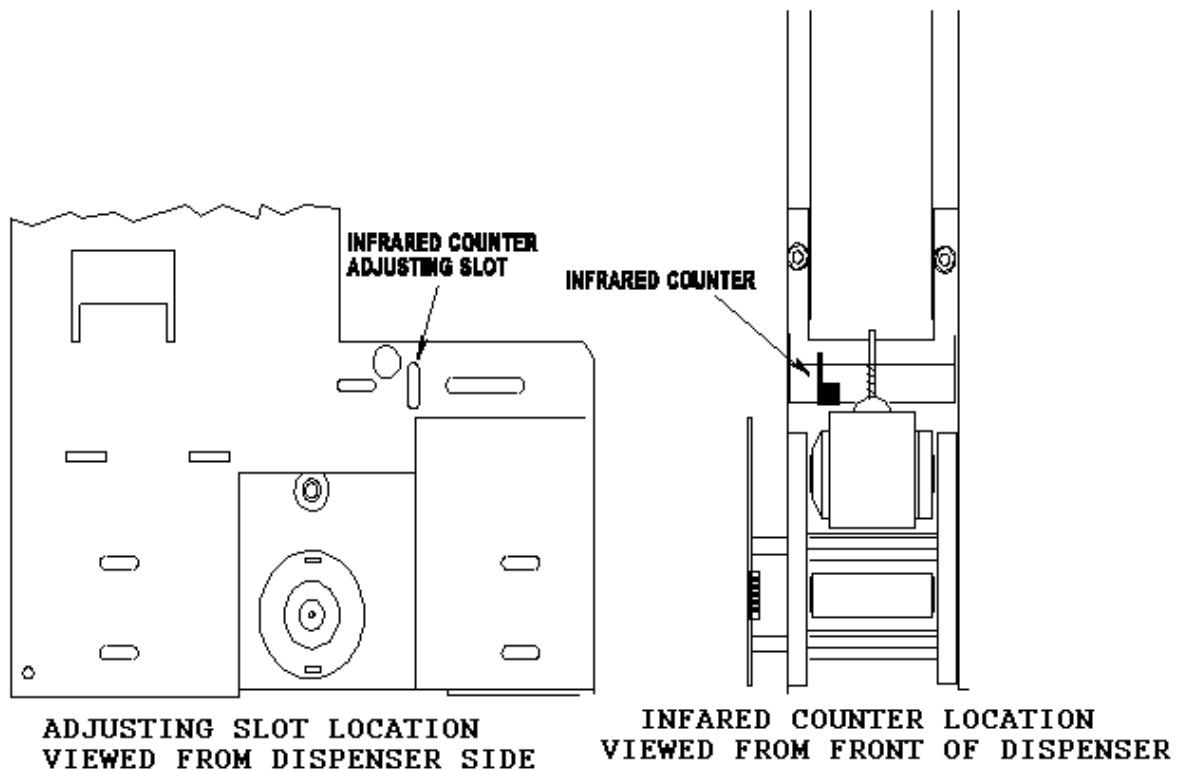



## Emptying the Cash

In order to empty the cash from the bill acceptor, follow these steps:

1. Unlock main cabinet door and swing out of the way.
2. Enter your PIN number.
3. Unlock and open the bill acceptor door.
4. Remove the cassette from the bill acceptor by pressing your fingers against both cassette latches. At the same time, rotate the cassette at an angle of about 15-20 degrees.
5. Pull the cassette off of the bill acceptor.
6. Open the cassette by rotating the lever at the back of the cassette, and remove the bills.
7. Reinstall the cassette.
8. Close and lock door.

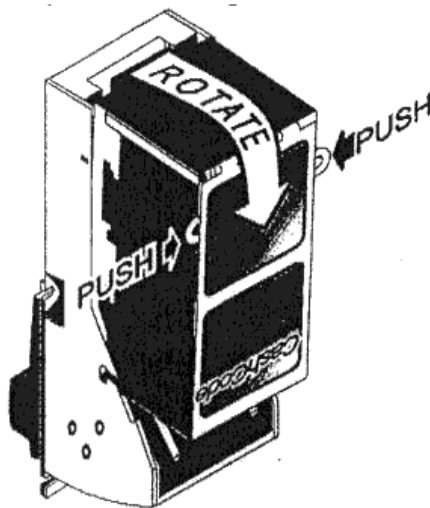

If your dispenser is equipped with a coin acceptor (selected models only), complete the following steps to empty the coins:

1. Unlock and open the coin acceptor door.
2. Remove and empty the coin box.
3. Reinstall the empty coin box.
4. Close and lock the coin acceptor door.

# Optional Report Printer

## Chapter

# 5

If your dispenser has the optional printer upgrade kit installed, the unit is capable of generating a hard copy report of all the accounting information in the unit. The unique design of the printer upgrade kit allows one printer to generate a report for any number of dispensers.

### Generating the Report

To print out the hard copy report, complete the following steps:

1. Unlock and open the main cabinet door and enter your four digit PIN #.
2. Plug the portable report printer into the telephone jack which is below the keypad inside the cabinet.
3. From the Main Menu press 7.

The printer will then begin printing a report similar to the one shown at right:



#### KING'S CROWN REPORT

MON OCT 16 2006  
10:52:56

SERIAL NUMBER:  
0000000

PIN POSITION #5

COLUMN #1  
PRICE: \$0.00  
TOTAL TICKETS DISPENSED: 0  
RESETTABLE TOTAL: 0

COLUMN #2  
PRICE: \$0.00  
TOTAL TICKETS DISPENSED: 0  
RESETTABLE TOTAL: 0

COLUMN #3  
PRICE: \$0.00  
TOTAL TICKETS DISPENSED: 0  
RESETTABLE TOTAL: 0

COLUMN #4  
PRICE: \$0.00  
TOTAL TICKETS DISPENSED: 0  
RESETTABLE TOTAL: 0

TOTAL OF ALL COLUMNS: 0  
RESETTABLE TOTAL: 0

TOTAL CASH ACCEPTED: \$0.00

RESETTABLE CASH TOTAL: \$0.00

-- END OF REPORT --



This report details all the accounting information present in the dispenser, including:

- The date and time the report was generated,
- The serial number of the dispenser,
- The PIN position # of the person generating the report,
- The price, total tickets dispensed and resettable total tickets dispensed by column,
- The total number of tickets dispensed in all columns,
- The resettable total number of tickets dispensed in all columns,
- The total amount of cash accepted and,
- The resettable total amount of cash accepted.

**NOTE:** If your dispenser does not have the optional printer upgrade kit installed, when you press 7 from the Main Menu, the display will read as follows:

**PRINTER OPTION  
REQUIRED**

After a short delay, the LCD will automatically return to the Main Menu.

(Contact your Bingo King Co. distributor if you would like this option.)

If you do not plug in the printer when you select 7 from the Main Menu, the display will read as follows:

**PRINTER NOT  
DETECTED**

After a short delay, the LCD will automatically return to the Main Menu. Plug in the printer, or turn the printer on and press 7 again.

## Player Information

Player instructions are located on the front of the dispenser underneath the bill acceptor.

### Dispensing Tickets

Players must check the LCD display for ticket dispensing instructions. The unit only accepts currency when the doors are locked and the bill validator light appears green. When the doors are locked and no credits appear, the LCD display appears as follows on models that accept **only bills**:

**INSERT MONEY**  
**\$1.00 TO \$20.00**

If your model accepts **both coins and bills**, the following display appears:

**INSERT MONEY**  
**\$0.25 TO \$20.00**

Once you insert money into the machine, you see:

**\$00.00 CREDIT**

Note that **\$00.00** represents the amount of the credit available.

### Selecting the PLAY ALL Button

Use the PLAY ALL feature to dispense 100 tickets maximum from a single column (or 100 tickets randomly from all columns set at the same price on random models). If all credits are not used up, the remaining credits will be displayed when vending is completed. When you select the PLAY ALL button, the following screen appears:

**\$00.00 CREDIT**  
**PLAYALL**

### Selecting a Column Button

You can dispense tickets one at a time by selecting a particular column. When you select a column, the following display appears on the LCD:

**\$00.00 CREDIT**  
**COLUMN X**

Note that the column number selected appears, not x.

On random models, a single ticket will be dispensed randomly from any column set at the chosen price.

## Care and Maintenance

Your model of the King's Crown™ Pull Tab Dispenser has been manufactured to exceed mechanical and electronic standards. The following information will assist you in the care and maintenance of your unit.



- Keep the unit dry. If it gets wet, wipe it dry immediately. Liquids can damage the electronic circuits.
- Wipe the unit with a damp cloth and a drop of liquid fabric softener to keep it looking new. Do not use any abrasive cleaning materials or solvents to clean your model.
- Handle any removed parts gently and carefully. Dropping or mishandling parts can damage electronic components.
- Use plastic cleaning implements or a soft cloth to remove dust from inside the unit. Metal tools can damage the electronic components.
- Use light lubricants and precision oiling implements to lubricate the rollers, shafts and the chute door.

### Lubricating the Chute Door

When dust from the tickets accumulates, the chute door can stick or become difficult to open or close. To prevent this from happening, lubricate the four pins on the chute door every three to six months. Using an aerosol lubricant with a straw attachment, spray each of the four pins carefully.

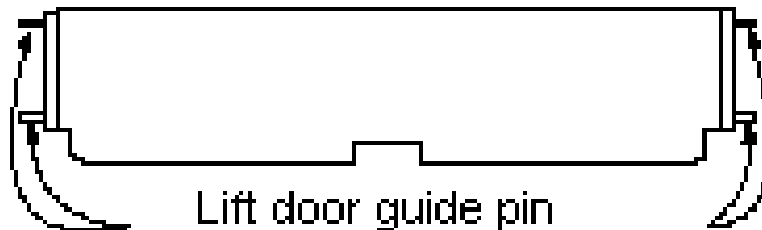

Lift door guide pin  
lubrication points

### Lubricating the Accelerator Roller Shafts

Occasionally, the accelerator rollers can grind or squeal. To prevent this from happening, you should lubricate the rollers and the transfer shaft every three to six months. Using any light lubricant and a precision oiler, put a drop of oil on each side of the accelerator roller and the transfer bottom shaft. **Do not get any oil on the rubber surface.**

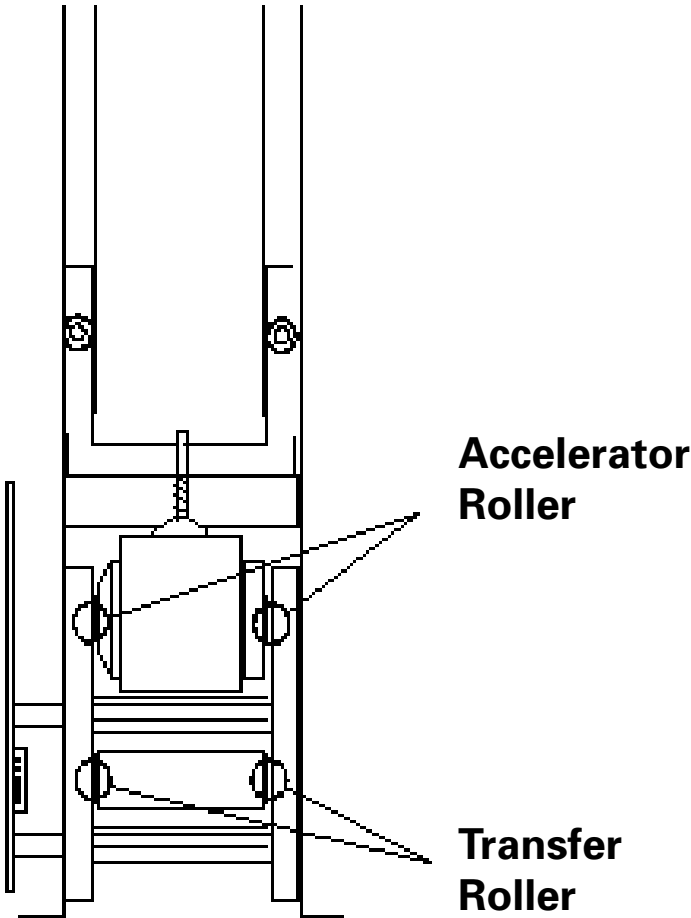

## **Cleaning the Infrared Sensor**

About every 100,000 tickets or three months, you should remove any dust build-up from the ticket counter infrared sensor. Failure to do this could result in miscounting of tickets. To clean the sensor:

1. Looking from the front of the dispenser, insert a Q-Tip, underneath the sensor.
2. Gently rub the bottom of the sensor to remove the paper dust, or
3. Use a can of compressed air to blow out the dust.

**Do not get too close. Compressed air can be very cold and/or expel propellant during delivery, and could lead to premature sensor failure.**

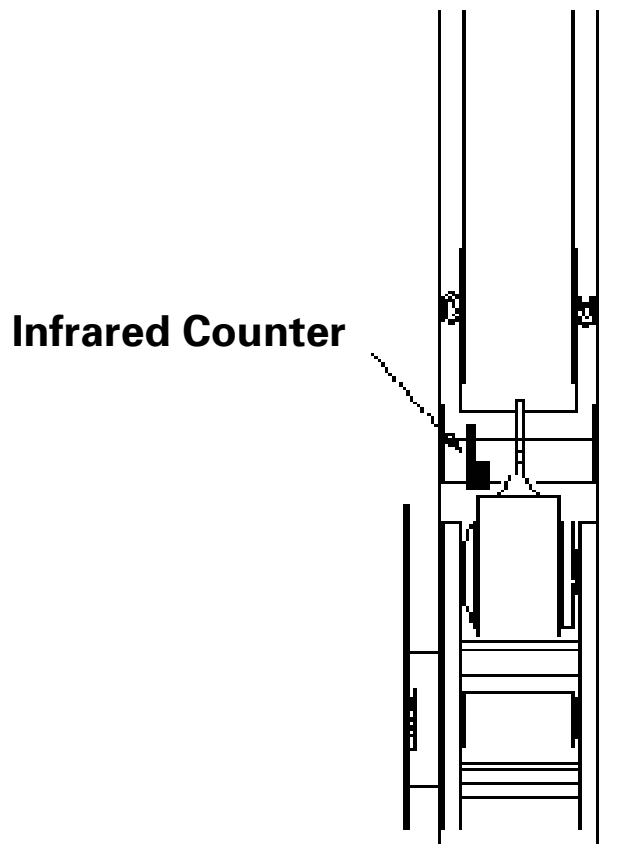

**Infrared Counter Location  
Viewed From Front of Dispenser**

## **Cleaning the Bill Validator**

A build up of dust and dirt in the bill validator may affect the acceptance rate of genuine bills. To prevent this, you should clean the bill validator every 3 months. To clean the validator, complete the following steps:

1. Remove the cassette from the bill validator. (See page 21).
2. Open the two covers of the banknote pathway by pressing the button labeled “PUSH”.
3. Use a soft cloth or brush to gently clean the optical sensors and bill pathway. Do not get fingerprints on the optical sensors.
4. To clean the magnetic heads, moisten a cloth with soap and water and gently rub the heads.
5. **DO NOT OIL THE BILL VALIDATOR** – Oiling of validator will void the warranty.



## **Cleaning the Coin Acceptor**

A build-up of dust and dirt in the coin acceptor may affect the acceptance of genuine coins. To prevent this, the coin acceptor should be cleaned every 3 months. To clean the acceptor, complete the following steps:

1. Open the spring-loaded hinged cover on the left side of the acceptor.
2. Using a damp cloth, wipe clean.
3. Let acceptor dry thoroughly before reinstallation.

## **Cleaning Jammed Bills**

If a severely damaged or wet/damp bill is inserted into the bill acceptor, there is a possibility that the bill may jam when it goes into the stacking cassette. To remove a jammed bill,

1. Remove the cassette carefully, trying not to damage the jammed bill (See page 21).
2. Open the two covers of the banknote pathway by pressing the button labeled “PUSH”.
3. Remove the jammed bill.



## Replacing a Ticket Column

If a ticket column requires replacement, complete the following steps:

1. **Unplug the dispenser.**
2. **Disconnect the battery wire. (See Page 7)**
3. Loosen the column retaining plate that is located beside the wide opening between every second column. Use a 3/8 inch socket wrench to loosen the nut and rotate the plate from its horizontal to a vertical position.

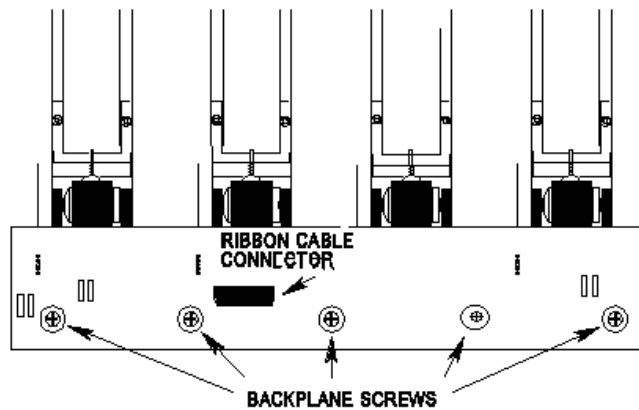
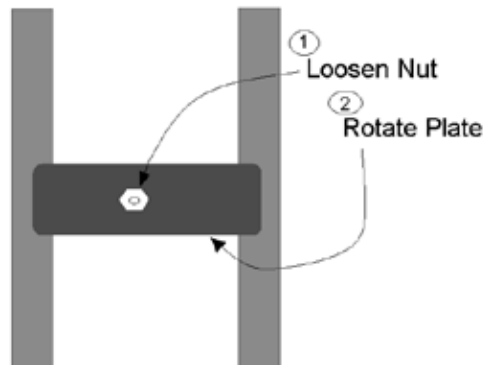

4. Disconnect the 14 Conductor Ribbon Cable located on the back plane and remove the five Philips screws from the backplane.
5. Pull the backplane circuit board straight out to disconnect the pins from the columns.
6. Place the circuit board, with the pin connectors facing up, on a level surface to avoid damaging the pins.
7. Place one hand on the top of the column, one hand on the bottom of the column and slide the column out of the unit.
8. Slide the new column in, making sure that the column fits in properly.

- a. Align the pins on the backplane circuit board with the plugs on the column circuit boards. (You may have to adjust the position of the columns slightly to ensure this.)

**NOTE:** You must ensure that the pins are aligned correctly. Push the pins gently in place.

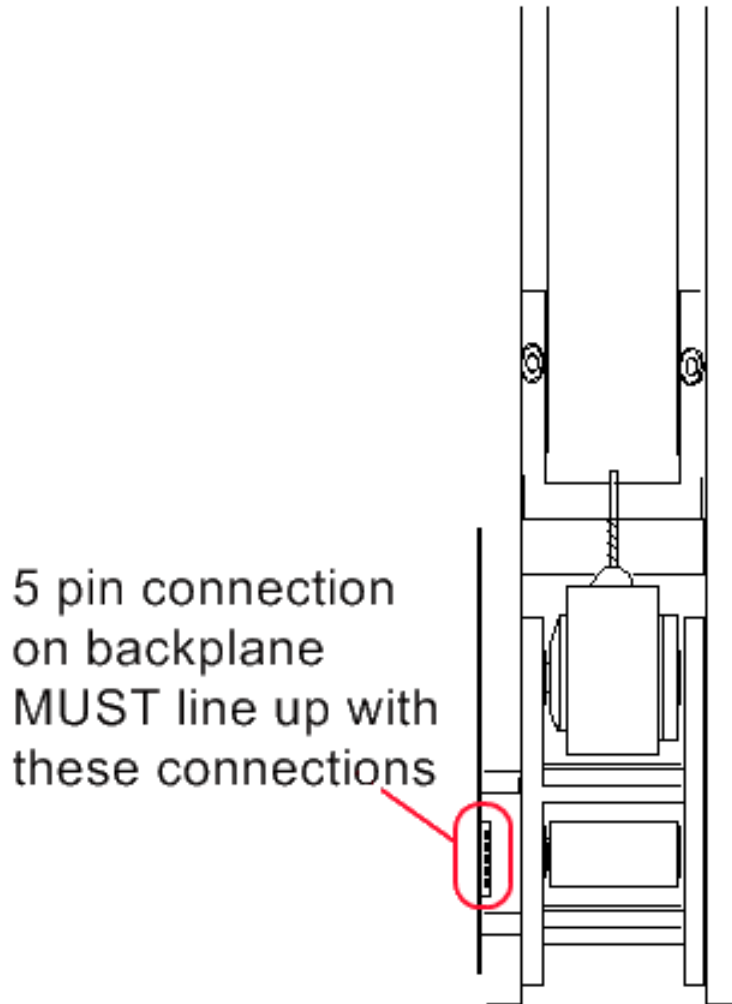

- b. Put the circuit board in place and screw in the five screws. Replace the 14 Conductor Ribbon Cable.
- c. Return the retaining plate to the horizontal position and tighten the retaining plate.
- d. Connect the battery. (See page 7 for details.)
- e. Plug in the unit.
- f. Test vend tickets from each column to ensure that the circuits are connected. (See page 15 for testing instructions.)

## Adjusting For Different Ticket Thickness

The King's Crown Pull Tab Dispenser adjusts to accommodate tickets that vary in thickness. To make the adjustment, you require one 11/32 inch socket.

1. Loosen the gate height adjustment nuts on either side of the ticket feeder.

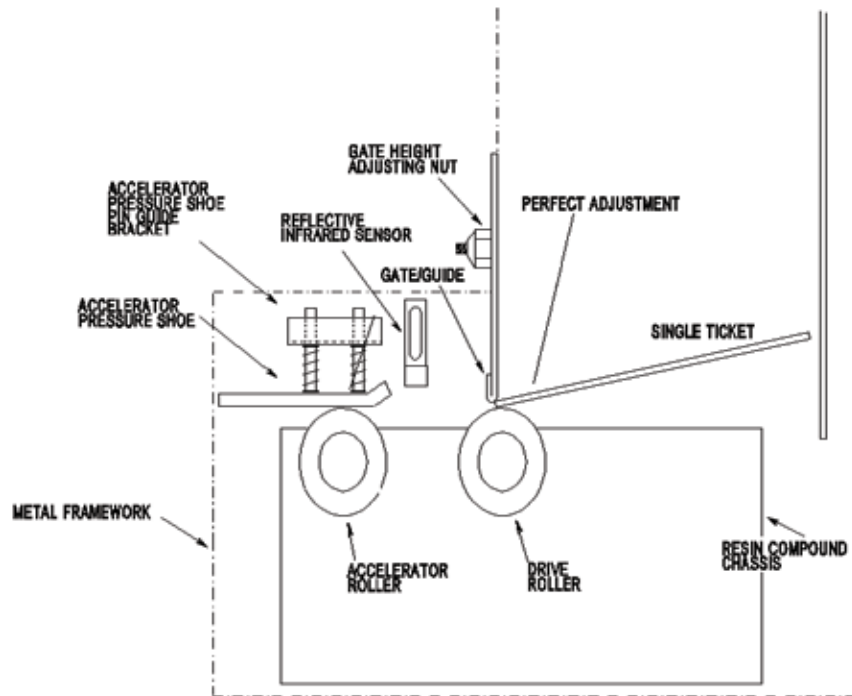

2. Adjust upwards for thicker tickets. Adjust downwards for thinner tickets.
3. Test adjustment.
  - Slide a single ticket down the ticket chute.
  - If the ticket slides through the feeder, the gap is too wide for the ticket. Adjust downwards.
  - If the ticket does not feed through the feeder when the large white gear is turned, the gap is too narrow for the ticket. Adjust upwards.
  - If the ticket stops at the front edge of the stainless steel gate and moves forward when the large white gear is turned, the adjustment is complete.

**Notice that the ticket is sitting in the column at an angle.**



4. Tighten the nuts gradually, alternating from side to side to ensure that the tooth of the gate stays parallel with the ticket.

**Do not over tighten.**



5. Test vend tickets from each column to ensure that the correct number of tickets dispense. (See page 15 for testing instructions.)

**NOTE:** The dispensing columns are factory preset to accept tickets .024 inches thick. You do not have to adjust the columns unless you are using a ticket which is a different thickness.



Ticket thicknesses can vary due to storage conditions. Humidity, heat, or cold can sometimes vary the ticket thickness or severely warp the ticket. To insure proper operation, store your tickets in a cool dry place away from direct sunlight.

## **Random Number Generator Features**

### **OPTIONAL RANDOM TICKET DISPENSE:**

When in random dispense mode, the “Play All” switch will randomly select up to 100 tickets from columns until credits are depleted. Only columns that are of the same price will dispense tickets.

If you would like this function installed, contact your local Bingo King Co. distributor for more information.

You will need to set pricing on at least 2 columns to be able to use the “Play All” function when in random dispense.

# Troubleshooting

## Chapter

# 8

Problem	Explanation
An incorrect number of tickets continue to dispense from a column.	<ol style="list-style-type: none"><li>1. Check ticket pricing for the column. Make sure that the price of the ticket matches the price set for the column; or</li><li>2. Clean the infrared sensor, see page 27.</li><li>3. Check the infrared sensor. Make sure the sensor is aligned. If the sensor is out of place, see page 20 for details on aligning the sensor.</li><li>4. Check gate adjustment, page 31.</li></ol>
Remaining credits do not dispense after the AC power is disconnected.	Connect the back-up battery. See page 7 for details.
Credits display but no tickets dispense.	Check the value of the tickets in the dispenser. If the remaining tickets in the dispenser are not divisible by the credit amount; for example, a \$1.00 credit displays, but the machine has only \$2.00 tickets. <ol style="list-style-type: none"><li>1. Enter more money.</li><li>2. Fill an empty column with a ticket of a different value. See Loading Tickets on page 10 for details.</li></ol>
LCD displays text but the back lighting is not on and the bill acceptor light is red.	No AC power to unit. Make sure AC power supply is plugged in and the ON/OFF switch is ON.
Bill acceptor does not accept currency and the indicator light remains red.	<ol style="list-style-type: none"><li>1. Check the amount of credit already established. If more than \$80.00 worth of credit appears, tickets must be dispensed until a credit value of \$80.00 or less appears; or</li><li>2. Check to ensure that the cabinet door is locked. No cash is accepted when the cabinet door is open; or</li><li>3. Check to see if the bill acceptor is full. No cash is accepted when the bill acceptor is full. See page 21 for instructions on emptying the bill acceptor</li><li>4. Check bill validator diagnostics, page 35.</li></ol>

<b>Problem</b>	<b>Explanation</b>
Tickets do not dispense.	Check the chute door. Tickets do not dispense when the chute door is not completely closed. Lubricate the chute door if necessary, see page 25.
Column makes grinding or squealing noise when tickets are dispensing.	Make sure that the unit has been properly maintained. Refer to page 26 on how to lubricate the roller shafts.
Tickets do not dispense from column selected.	Is your dispenser a random select model? Tickets will randomly dispense from all columns set to the same price as the column selected.
“COLUMN EMPTY OR MALFUNCTION” appears on the LCD.	<ol style="list-style-type: none"> <li>1. The column selected does not have any tickets loaded. Load more tickets into the column. See page 10.</li> <li>2. On random select models, at least two columns must be set to the same price AND have tickets loaded. See page 10 for loading tickets and page 14 for setting ticket pricing.</li> <li>3. A ticket could be jammed in the column. See page 19 to clear the jam.</li> </ol>
Alarm activated.	<ol style="list-style-type: none"> <li>1. Make sure that the cabinet doors are closed and locked. The alarm will sound if any one of the cabinet doors is open and the ticket pricing has already been set; or</li> <li>2. Make sure that the unit is plugged in. The alarm sounds if the unit is unplugged for more than seven seconds; or</li> <li>3. A power failure lasting more than seven seconds causes the alarm to sound.</li> </ol> <p>To reset the alarm:</p> <ul style="list-style-type: none"> <li>• Open door.</li> <li>• Enter PIN number.</li> <li>• Close and lock door.</li> <li>• Plug in, if unplugged, or wait for power to be restored.</li> </ul>
CLOCK OPTION REQUIRED or PRINTER OPTION REQUIRED appears on the LCD	Your dispenser is not equipped with the optional printer upgrade kit. The option on the main menu which was selected is not available until the printer upgrade kit is installed. Contact your Bingo King Co. distributor for information on obtaining this kit.

## Bill Validator Diagnostics

If the red light on the front of the bill validator is ON when the doors are locked and no credit appears, insert a bill and remove it. After the red light goes OFF, count the number of times the light flashes, and compare it with the chart below:

# of Flashes	Explanation
0	No faults - Validator is working properly.
1	The cassette is removed from the bill validator. Install the cassette. See page 21 for information on the cassette.
2	The stacking motor does not rotate. Possible jammed bill. See page 28 to clear the jam.
3	The cassette is full. Empty the cassette (see page 21 for information on emptying the cassette).
4	A mechanical jam in the cassette. See page 28 to clear the jam.
5	There is a stacking motor electrical overload. Contact your Bingo King Co. distributor.
6	Failure of optical sensors occurred. Clean the sensors (see page 28).
7	Failure of magnetic sensors occurred. Clean the sensors (see page 28).
8	The transporting motor does not rotate. Clean the bill pathway (see page 28) or clear a jammed bill (page 28).
9	The speed of the transporting motor is too fast. Contact your Bingo King Co. distributor.
10	There is a transporting motor electrical overload. Contact your Bingo King Co. distributor.
11	The bill pathway security latch is open. Close the latch.
12	The banknote is in the entry slot of the cassette and credits were not issued. Contact your Bingo King Co. distributor.

Note that if the red light on the front of the bill acceptor did not go OFF when a bill was inserted, a failure in communication between the bill acceptor and the CPU of the dispenser has occurred. Contact your Bingo King Co. distributor.

When the diagnostics are complete, the red light stops flashing.

## Specifications

### Physical Characteristics

Power Supply Input:	110/120V AC
Power Supply Output:	16V AC
Operating Temperature:	40 to 95 °F (5 to 35 °C)
Power Consumption:	40VA Max.

Dimensions:	<b>4-Column</b>	<b>8-Column</b>
Width:	24 1/2 inches	42 5/8 inches
Depth:	15 1/4 inches	15 1/4 inches
Height:	36 5/8 inches	36 5/8 inches
Weight (empty):	110 lbs.	190 lbs.



# Chapter 10

## Diagrams and Pictures

### Column Exploded View

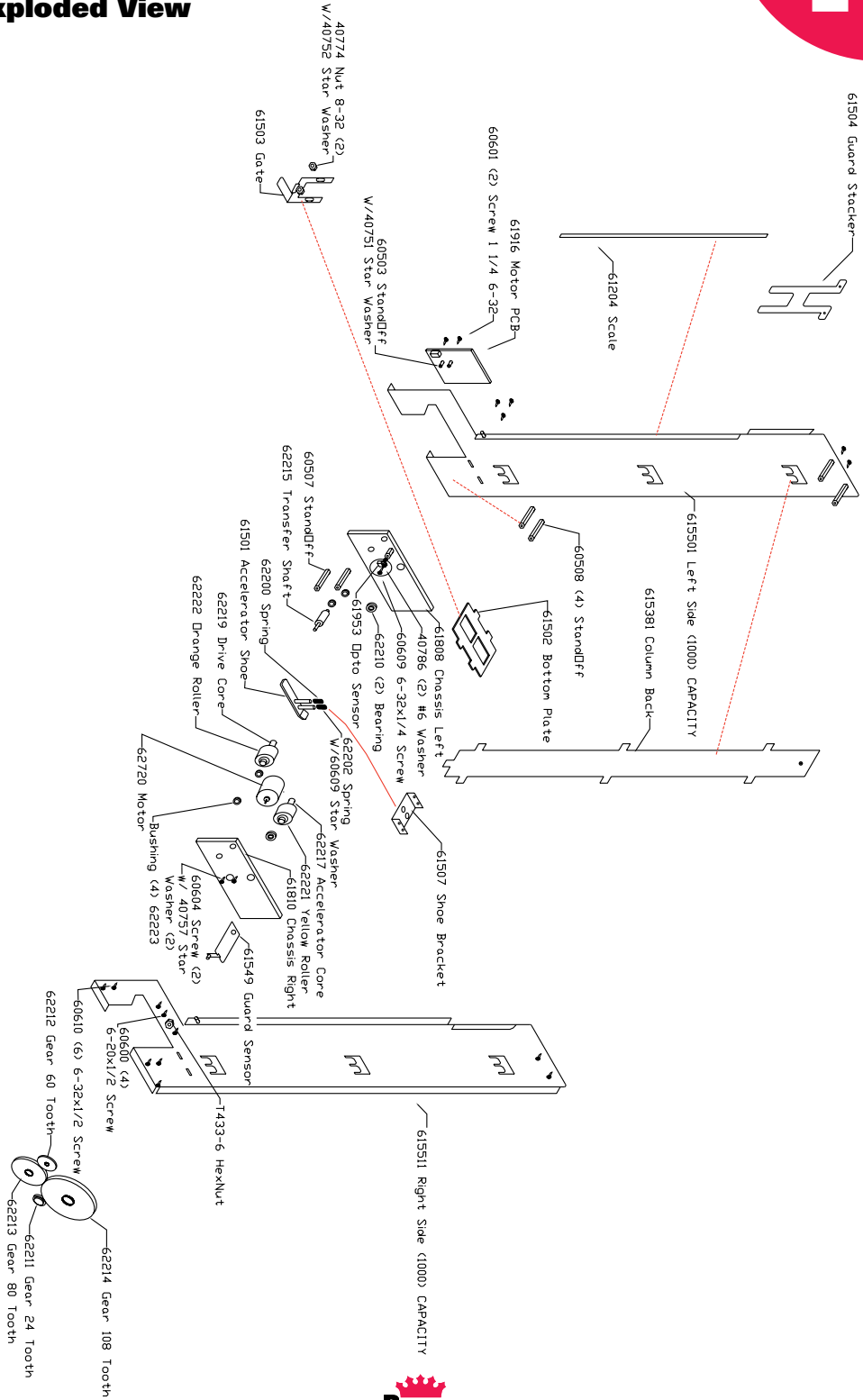

## Bill Acceptor Door Assembly

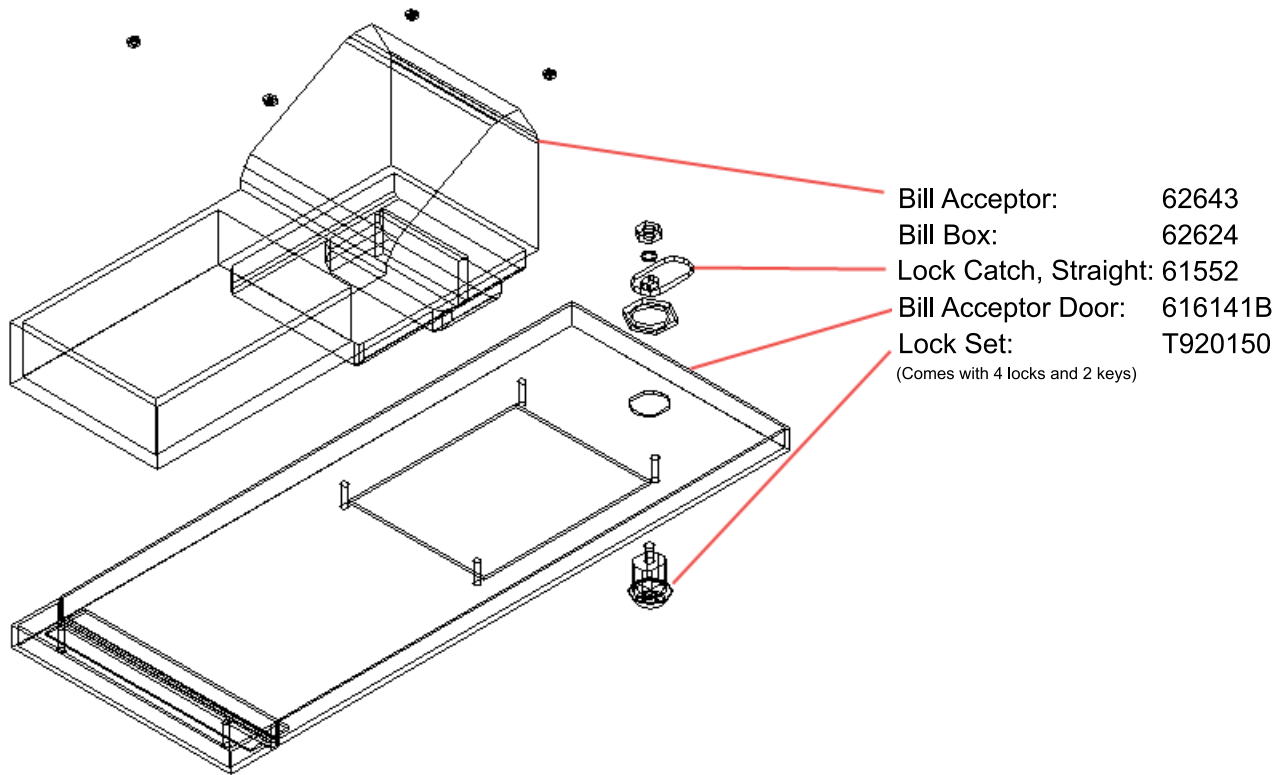

## Roller Carriage Assembly

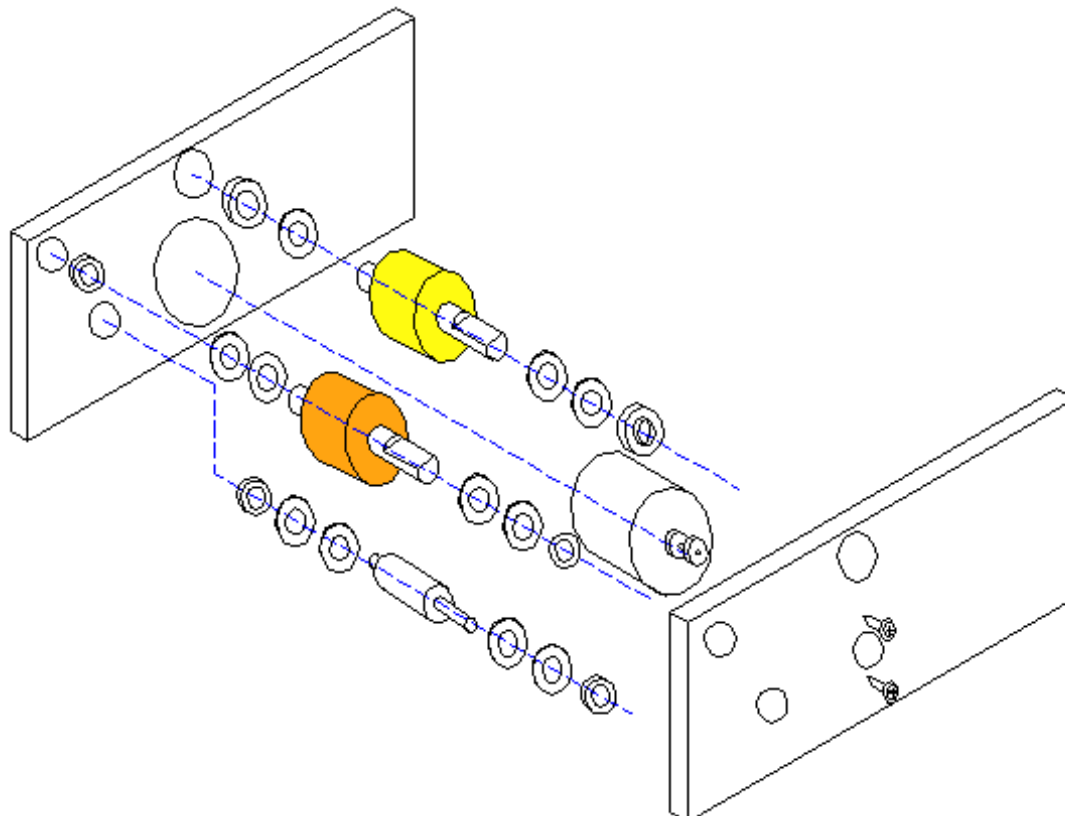

# Keypad Assembly

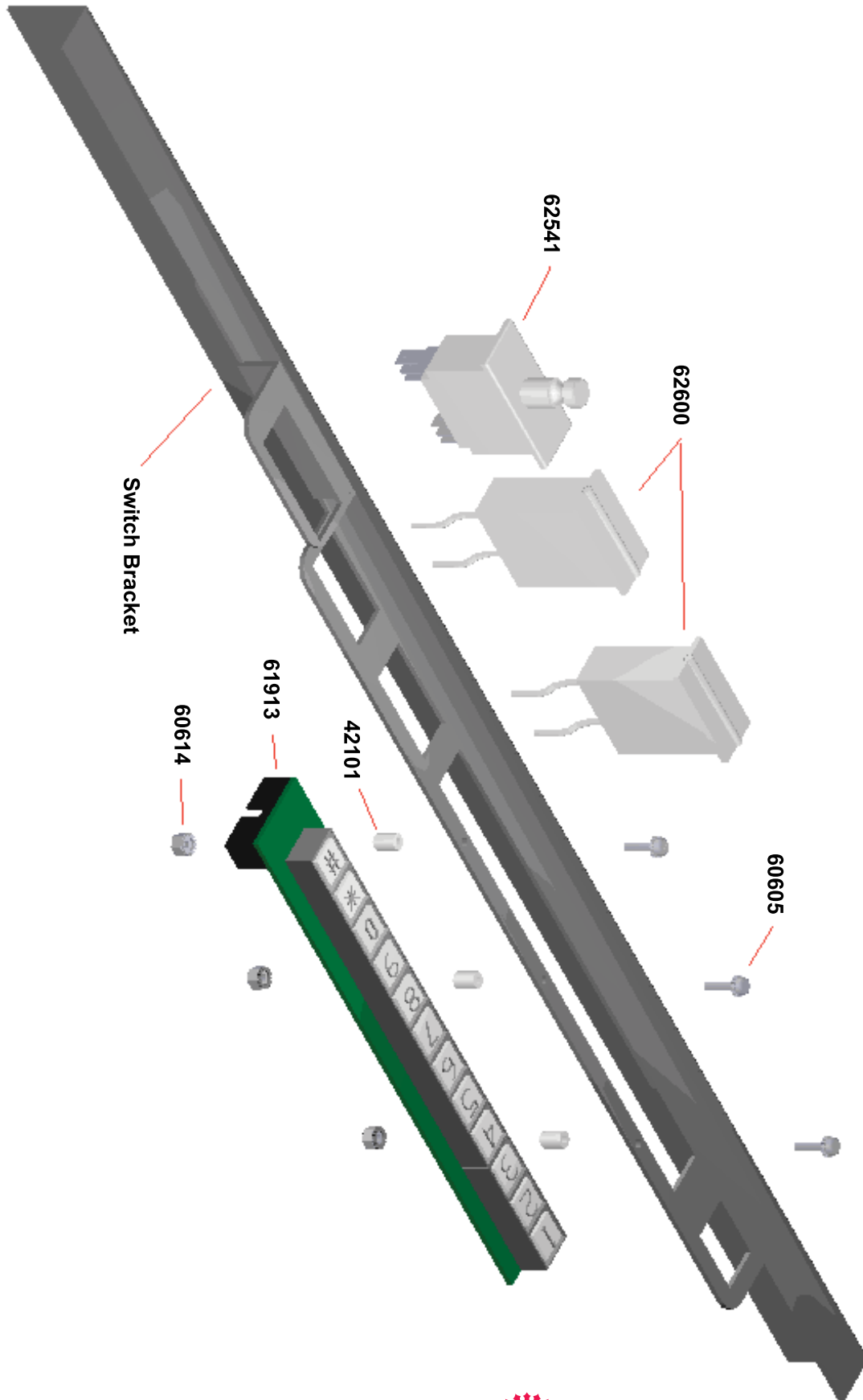

# Printed Circuit Board Layout

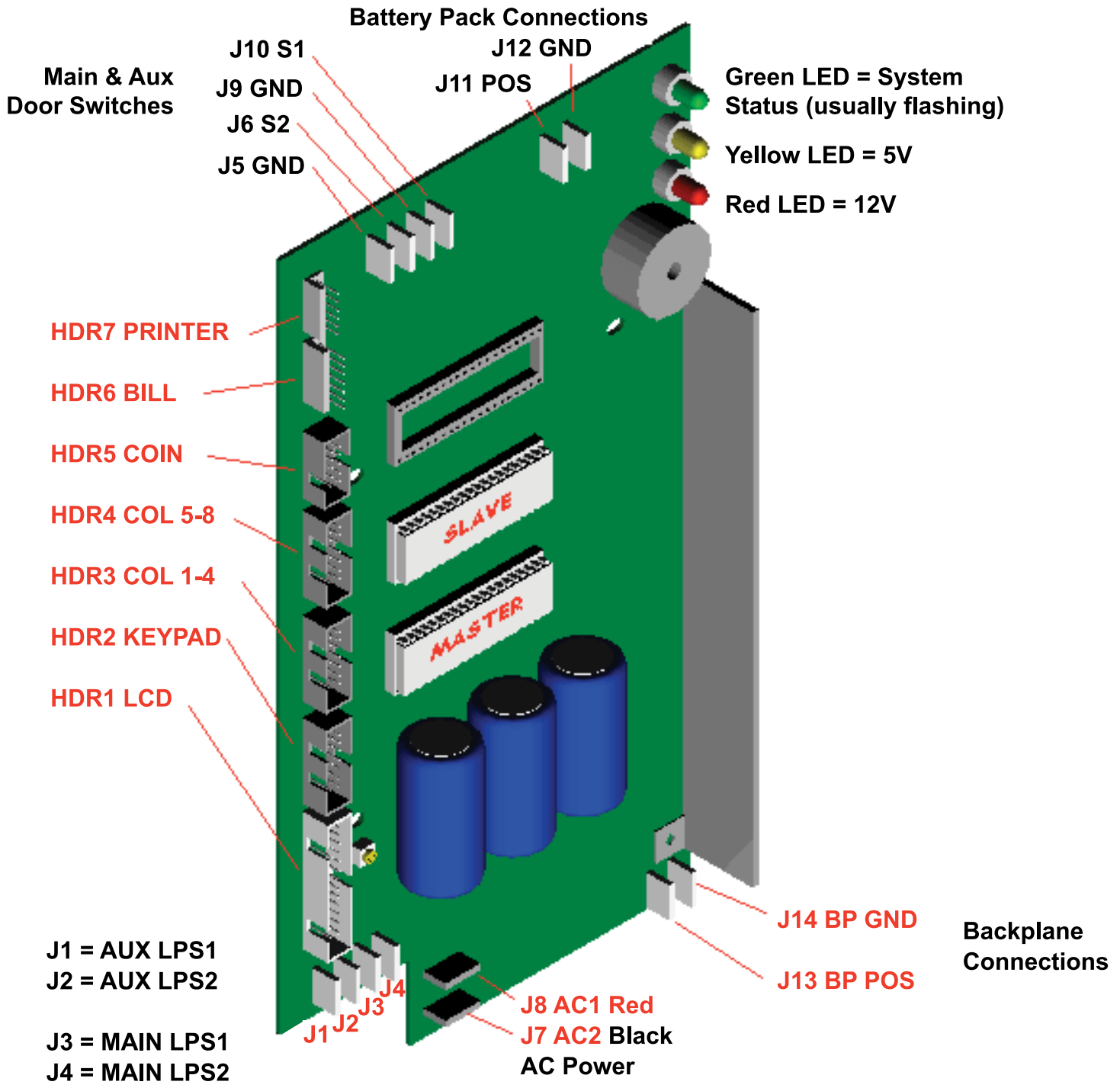

## Parts List, Column

61501	Accelerator shoe
61507	Accelerator shoe bracket
61504	Column ticket retaining plate
62213	Gear, connector 80 tooth
62214	Gear, large 108 tooth (used w/ yellow roller)
62211	Gear, motor drive 24 tooth
62212	Gear, small 60 tooth(used w/ orange roller)
62720	Motor, Igarashi
61953	Optical sensor – sensor and wire only
61549	Optical sensor guard
61916	PCB, column drive
62217	Roller core, orange (just the shaft – needs 62222 for rubber)
62219	Roller core, yellow (just the shaft – needs 62221 for rubber)
62222	Roller, orange (just the rubber – order shaft and have assembled)
62221	Roller, yellow (just the rubber – order shaft and have assembled)
606060	Screws, mounting (accelerator shoe bracket to column)
61204	Sign, column scale
62202	Spring, accelerator front (pushes accelerator shoe down)
62200	Spring, accelerator rear (also need 40786) (pushes accelerator shoe down)
607124T	Ticket column (1000 capacity)
61503	Ticket gate, metal
40125	Ticket spacer, magnetic (only needed for some very short tickets for proper alignment within the column)
40786	Washer (use w/ 62200)

## Parts List, Main Cabinet

62705	Battery, backup
616141B	Bill acceptor door (w/ flange, new style)
62643	Bill acceptor, US currency
62624L	Bill Box w/ Lock, 600 bill capacity
62624	Bill Box, 600 bill capacity
64520	Cable, backplane ribbon (COL 5-8)
645191	Cable, backplane ribbon, New CPU PCB (COL 1-4)
645222	Cable, keypad (14.5" long)
645211	Cable, LCD ribbon
615531	Chain Hook, Metal (holds chain to validator door)
64524B	Console control, keypad model (Remote hand held)
61804	Console door assembly, lexan (slide door on lower door assembly)
61505	Console latch (left cabinet)- uses spring 62201 (2, 4, & 8 column)
61506	Console latch (right cabinet)- uses spring 62201 (8 column only)
61802	Deflecting film, lexan
431445	Keys, Serialized cabinet & Bill Acceptor door (May not be able to match your particular machine's key serial number. Lock replacement maybe necessary.)
619091	LCD board Rev 2 (connector lugs are straight – as opposed to bent)
60616	Leveling foot w/ nut (each)
61922	Light Kit, 4 & 8 column (LED bar @ top of columns)
61924	Light Kit, Ticket door (LED bar in ticket delivery door)
626241	Lock set, bill stacker (locks bill box – 1 lock & 1 key)
T920150	Lock sets, 2 main cabinet door (4 locks & 2 keys)
61903	PCB, backplane, 4 column, Left Side
619030	PCB, backplane, 8 column, Right Side

## Parts List, Main Cabinet (cont'd)

61916	PCB, column drive
619191	PCB, CPU cash fed, Non-Random – REV 1
61920	PCB, CPU for keypad
645111	Power supply jack & wiring (Wiring inside of the machine)
62700	Power supply, King's Crown (16 volts AC)
612021	Sign, column select (1-4)
612031	Sign, column select (5-8)
61201	Sign, instruction (NO CHANGE GIVEN, \$.25 - \$20)
61200	Sign, instruction (NO CHANGE GIVEN, \$1 - \$20)
62201	Spring, console door (used on console latches)
62504	Switch, cash door (black switch)
62502	Switch, column select button (comes w/ red button & switch)
61954	Switch, console door (mini switch for slide door)
62501	Switch, main door (white switch – can be pulled out for interlock)
64517	Wiring harness, backplane power (column 5-8)
645051	Wiring harness, backplane power, cash fed (column 1-4)
64505	Wiring harness, backplane power, keypad (column 1-4)
645161	Wiring harness, battery
61400	Wiring harness, Power, for 62643 (Validator Power Harness) also need: 4 x 60510 (pins) & 4 x 42815 (spiro wrap) to properly replace cable

# Warranty

## Chapter

# 11

### **Bingo King® Bingo Console Standard Limited Warranty**

Set out below are the terms of the Standard Limited Warranty (“Limited Warranty”) made by Bingo King Co. (“Bingo King”) in connection with the sale of the Bingo King equipment (the “Equipment”).

#### **1. Limited Warranty**

Subject to the limitations in the next paragraph, Bingo King warrants to the original purchaser (“Purchaser”) that the Equipment will, to the extent manufactured by Bingo King, be free from defects in material and workmanship for a period of ONE (1) YEAR from the date of shipment of the Equipment from Bingo King. Purchaser represents to Bingo King that no employee, agent, or representative of Bingo King (or a Bingo King dealer) has made any representation or warranty regarding the Equipment except as set out herein.

This Limited Warranty applies to normal commercial use and does not cover failure or damage which (a) occurs in shipment; (b) is caused by products not supplied by Bingo King; or (c) results from accident, misuse, abuse, neglect, mishandling, misapplication, alteration, set-up adjustments or modifications. This Limited Warranty also does not cover any damage resulting from failure to install the Equipment in strict conformity with local fire and building codes and regulations, or if the installation does not comply with the installation instructions provided by Bingo King. Products which are manufactured by a third-party vendor and offered with the Equipment (such as monitors, keyboards, cameras, and other peripheral products) are not covered by this Limited Warranty. Purchaser needs to consult the third-party manufacturer’s warranty for warranty claims related thereto. Bingo King will supply a copy of any third-party vendor’s warranty upon written request.

#### **2. Disclaimer of Warranties**

BINGO KING MAKES NO WARRANTIES, EXPRESS OR IMPLIED (INCLUDING, WITHOUT LIMITATION, MERCHANTABILITY, FITNESS FOR PARTICULAR PURPOSE, OR AGAINST INFRINGEMENT OF ANY PATENT), EXCEPT AS EXPRESSLY PROVIDED HEREIN. THE EXPRESS WARRANTIES PROVIDED HEREIN ARE IN LIEU OF AND EXCLUDE ALL OTHER WARRANTIES, GUARANTEES OR REPRESENTATIONS, EXPRESS OR IMPLIED, WHETHER ARISING BY OPERATION OF LAW OR OTHERWISE.

#### **3. Limitation of Remedies**

If the Equipment does not conform to the Limited Warranty set out above, Bingo King will, at its option, (a) repair or replace the Equipment, or part thereof, which is defective, or (b) refund so much of the purchase price as Purchaser has paid for the defective Equipment, less 1/12th of the purchase price for each month between the date of the purchase from an authorized Bingo King dealer and the date of the discovery of the defect, provided that written notice of the defect and its nature is given to Bingo King as soon as practical after discovery of the defect, but in no event later than 90 days from the date of the discovery of the defect. All part repairs are through the Bingo King Cleveland Depot.

#### **4. Limitation of Liability**

The remedy of repair, replacement, or refund of the purchase price is Purchaser’s sole and exclusive remedy and will satisfy all of Bingo King’s liabilities, whether based on contract, negligence, tort, product liability, strict liability or otherwise. IN NO EVENT WILL BINGO KING BE LIABLE FOR INCIDENTAL OR CONSEQUENTIAL DAMAGES, NOR WILL ITS LIABILITY IN CONNECTION WITH ANY EQUIPMENT OR SERVICE SOLD (INCLUDING NONDELIVERY OR LATE DELIVERY THEREOF) EXCEED THE SALE PRICE OF SUCH EQUIPMENT.



## **5. Warranty Voided**

Any obligations of Bingo King under this Limited Warranty will be deemed to have been satisfied if anyone other than an authorized Bingo King Equipment Dealer services the Equipment.

## **6. Transfer of Limited Warranty**

Purchaser may transfer its rights under this Limited Warranty, subject to the terms and conditions hereof, to a buyer ("Buyer") from Purchaser of the Equipment. Thereafter, the rights under this Limited Warranty are not transferable.

For the transfer by Purchaser of the Limited Warranty to be effective, the following conditions must have occurred no later than the 30th day following the date of resale to Buyer:

- A. Purchaser must have complied with all requirements to make the Limited Warranty effective as to Purchaser; and
- B. The Equipment (as an entire unit and as purchased by Purchaser) must be transferred to Buyer.

Upon an effective transfer of this Limited Warranty, Buyer will be considered to be "Purchaser" for paragraphs 1, 4 and 8 hereof.

## **7. Inspection**

With respect to any claim that the Equipment is defective, Bingo King will be allowed a reasonable time to inspect the Equipment, in place. If the Equipment is altered or removed before Bingo King has made such inspection or waived its right to do so, the obligations of Bingo King under this Limited Warranty will be deemed to have been satisfied.

## **8. Proof of Purchase**

Notwithstanding anything to the contrary in this Limited Warranty, Purchaser must, upon Bingo King's request, submit proof of original purchase (satisfactory to Bingo King) of the Equipment. The Limited Warranty set out above shall not apply to, nor cover, any Equipment for which Purchaser is unable, upon Bingo King's request, to supply such proof of purchase.

## **9. Telephone Support**

Telephone support is available to Purchaser on Mondays through Fridays (including holidays) from 8:00 a.m. until 12:00 a.m. (Eastern Standard Time). The telephone number is (866) 405-3482.

## **10. Preventative Maintenance; Emergency Service**

Purchaser is entitled to request Bingo King to perform, through an authorized Bingo King distributor, one (1) preventative maintenance servicing on the Equipment. The preventative maintenance servicing shall be done in accordance with Bingo King's standard Preventative Maintenance program. Service performed by Bingo King or an Bingo King authorized distributor, which is not covered under its standard Preventative Maintenance program, will be billed to Purchaser.

## **11. Limitation of Actions**

Any legal action against Bingo King for a default of its obligations under this Limited Warranty must be commenced within two (2) years from the date the Equipment was sold by an authorized dealer of the Equipment.



## 12. How to Obtain Service

If a problem with this Equipment develops during or after the warranty period, proceed as follows:

- A. Refer to your Operator's Manual and follow the Troubleshooting Table within the 'Service Section'.
- B. Contact the authorized Bingo King Equipment Distributor from whom you purchased the Equipment.
- C. Contact the Bingo King telephone support number listed above.

SERVICE CALLS WHICH DO NOT INVOLVE DEFECTIVE MATERIALS OR WORKMANSHIP AS DETERMINED BY BINGO KING IN ITS SOLE DISCRETION ARE NOT COVERED. THE COST OF SUCH SERVICE CALLS IS THE RESPONSIBILITY OF THE PURCHASER.

Bingo King wants you to remain a satisfied customer. If a problem occurs that cannot be resolved to your satisfaction, please contact us immediately, phone one of the numbers listed above or write to:

Bingo King Co.  
c/o National Service Manager  
2807 Lincoln Way  
Lynnwood, WA 98087

Please be sure to include the name, model number, serial number, date of original purchase, and the distributor from whom you purchased the Equipment, as well as any actions taken to correct the problem.





PART # BK68300



Bingo King Co. • 2807 Lincoln Way • Lynnwood, WA 98087 • 425.745.3700